

DESIGNER PROFILE / DAVID MORGAN

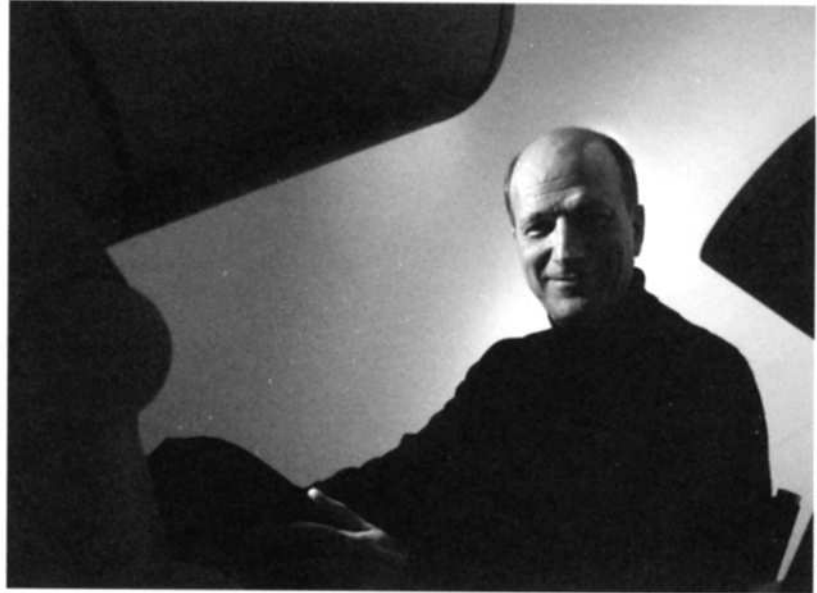

**SOLVING THE TECHNICAL PROBLEMS IS VERY SATISFYING, AS IS SEEING ONE'S PRODUCTS IN USE AROUND THE WORLD**

**Cristina Esposito** How did you get started as a designer of lighting products?

**David Morgan** I was always fiddling with bulbs and batteries as a child but was also very interested in painting and sculpture. I took a degree in physics, followed by a masters in industrial design. I worked at Thorn Lighting before I set up my own business. When I started out, product design wasn't talked about much. Manufacturers had some superficial interest, but didn't quite make the connection between design and commercial benefit.

**Cristina Esposito** How has technology affected product design?

**David Morgan** Although I have a project team of six, I am involved all the way through the design and development process. And it is partly the computer revolution that has allowed me to keep such a hands-on approach. Productivity among designers has increased substantially. The designer creates the 3D computer model on screen, it's sent to the factory and made directly from the CAD files. This process has been incredibly empowering.

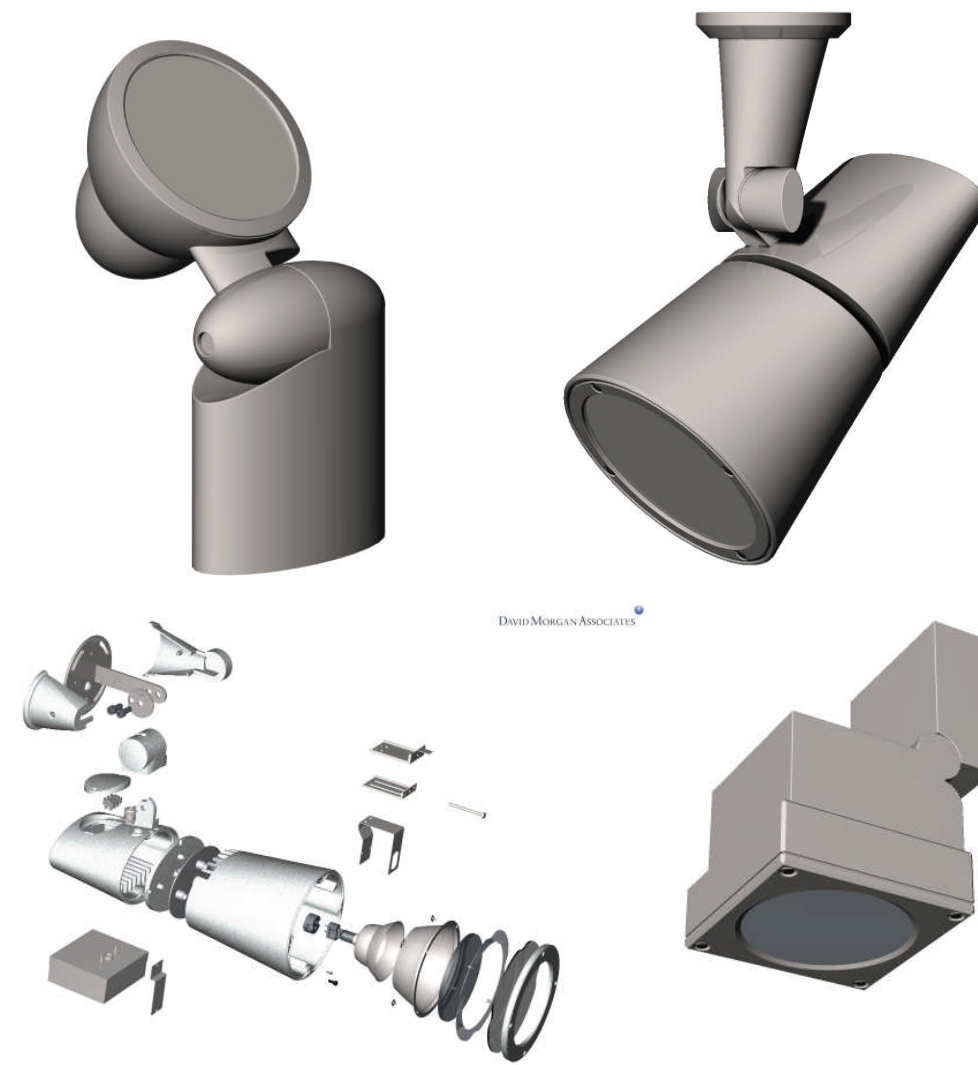

**NAME:** David L Morgan  
**COMPANY:** David Morgan Associates  
**BORN:** 1951, London  
**EDUCATION:** London University, Royal College of Art  
**EMPLOYMENT HISTORY:** Designer, Thorn Lighting 1976-79  
Designer, FM Design London 1979-81  
Founded David Morgan Associates 1981

- KEY DESIGNS:**
- Thorn Sunflood for Thorn Lighting, 1979
  - Holophane Wallpackette for Holophane Lighting, 1985
  - Holophane Terralux for Holophane Lighting, 1987
  - Burlington desk light for Panasonic, 1987
  - Euclid system for Axis lighting, 1991
  - Morph exterior spotlight for Louis Poulsen, 1995
  - Calisto range for Designplan lighting, 1995
  - Vertigo range for Designplan lighting, 1996
  - PAR spotlight range for Panasonic, 1997
  - Radiant xenon system for Belfer Lighting, 2001
  - SPR projector range for Louis Poulsen, 2003-2004

